

# EE 240 PCM ENCODER

## EE 246 Serial Packets Module

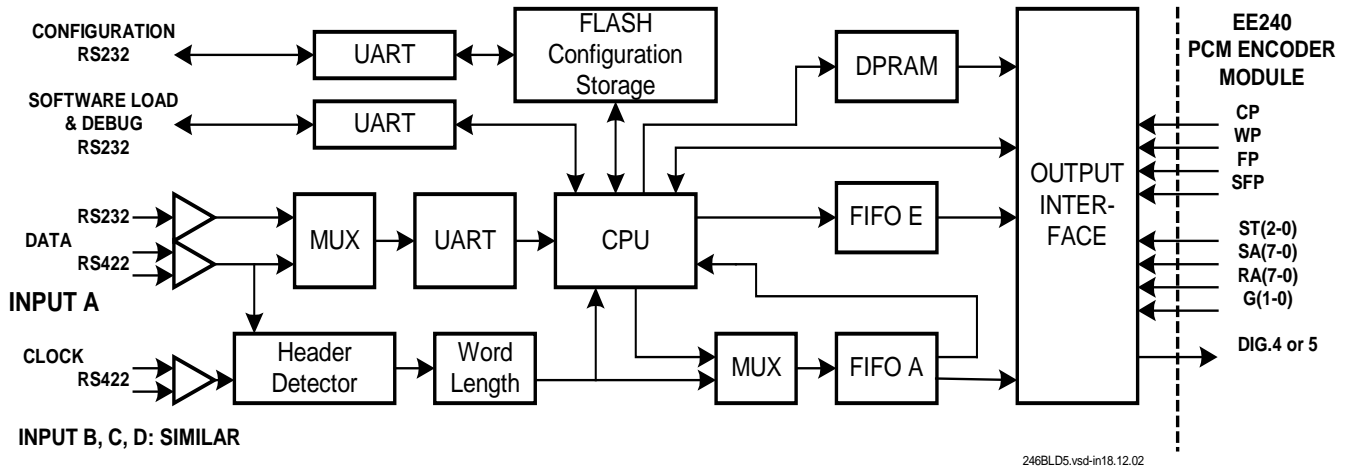

### EE240 PCM ENCODER System.

The **EE240** is a configurable **PCM Encoder** for analog and digital signal inputs. It has a modular design using plugin modules. The EE240 can be programmed with the **EE200 Format Generator** software to generate practically any type of PCM Format compatible to the **IRIG standard 106 class I**. Up to **8 independent PCM formats** may be downloaded via RS232 into the EE240 and stored. The EE240 is self-contained after programming. All input signals may be routed to any position of the PCM format, with **individual commutation rates**.

**EE236 Power Module.** 12 or 28 VDC.

**EE237 SSR Controller Module.**

EE235 Solid State Recorder with 256 MByte.

**EE238 SSR Memory Module.** 256-768 MByte.

**EE240 PCM Encoder Module.**

Optional EE878 Conditioning and Timing.

**EE242 Analog Signal Conditioning Module.**

32 Bridge inputs with filters.

**EE243 Digital Interfaces Module.**

32 On/Off and 4 frequency inputs.

**EE244 Thermocouple Module.**

32 inputs with filters.

**EE245 Charge Amplifier Module.**

32 inputs with filters.

**EE246 Serial Data Packets Module.**

4 RS232/422 configurable inputs.

**EE247 Analog Expansion Module.**

64 inputs, single-ended or differential.

**EE248 GPS Receiver Module.**

10 Hz GPS rx. Position and Raw data.

**EE249 Ethernet Module.**

2 LAN inputs for data to encoder.

**EE880 Analog Filter, 32 channel.**

Optional board for analog modules.

### EE246 Serial Packets Module.

- 4 configurable RS232/422 ACSII UART inputs for rates up to 921600 baud.
- 4 high speed burst packet inputs with NRZ+CP input rates to 10Mbps have 32-bit header detectors.
- Selected bytes of ASCII or burst packets are routed to the DPRAM. The EE240 reads specified addresses and place data in assigned word/frames of the PCM format.
- High speed burst packets are split into word-lengths, buffered in FIFOs and routed into selectable words of the PCM format.
- Data loading to the 240 interfaces can occur at Frame or Format start, or be asynchronous.
- EE246 is configured by sending text string packets from a PC over RS232. The configuration is stored in Flash memory.
- EE246 receives control and address lines from the EE240 module. All data is returned on one serial digital line, DIG4.
- The EE200 Format Generator software supports the addresses required for the EE246.

246ds31\_0304